

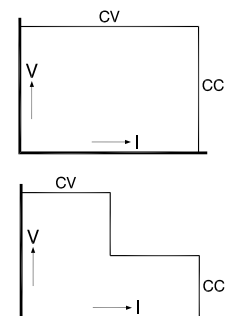

## SM 800 - Series 800 W DC POWER SUPPLY

Models	Voltage range	Current range
SM 7.5-80	0 - 7.5 V	0 - 80 A
SM 18-50	0 - 18 V	0 - 50 A
SM 70-AR-24 Autoranging output	0 - 35 V 0 - 70 V	0 - 24 A 0 - 12 A
SM 400-AR-4 Autoranging output	0 - 200 V 0 - 400 V	0 - 4 A 0 - 2 A



### Features

- Designed for long life at full power
- Excellent dynamic response to load changes
- Protected against all overload and short circuit conditions
- EMC surpasses CE requirements: low emission & high immunity
- Low audible noise: fans are temperature controlled
- Available options: High Speed Programming, Interfaces, Extra Isolation, Sequencer, Digital Encoders, Power Sink etc.

### Functionalities

- Master/Slave parallel and series operation with voltage and current sharing
- Stacking is allowed, space between units is not required
- High power system configuration from multiple units
- 19" rack mounting or for laboratory use (feet included)
- Remote sensing
- Interlock

	SM 7.5-80	SM 18-50	SM 70-AR-24	SM 400-AR-4
<b>Output</b> voltage current  AUTORANGING (2 ranges) max. output current / voltage	0 - 7.5 V 0 - 80 A  no -	0 - 18 V 0 - 50 A  no -	0 - 70 V 0 - 24 A  yes 24 A / 0-35 V 12 A / 35-70 V	0 - 400 V 0 - 4 A  yes 4 A / 0-200 V 2 A / 200-400 V
<b>Input</b> <b>AC</b> single phase, 48 - 62 Hz  <i>Power Derating vs input:</i> 90 V : P <sub>out max</sub> (W), I <sub>in</sub> (A) 100 V : P <sub>out max</sub> (W), I <sub>in</sub> (A) 110 V : P <sub>out max</sub> (W), I <sub>in</sub> (A)  <b>230 V : P<sub>out max</sub> (W), I<sub>in</sub> (A)</b>  power factor, 100%, 50% load  internal fuses standby input power (V <sub>o</sub> =I <sub>o</sub> =0) standby input power (V <sub>o</sub> =V <sub>max</sub> )	90 - 265 V  580, 8.5 600, 7.6 600, 6.9  600, 3.2  0.99, 0.96  12.5 AT 14 W 18 W	90 - 265 V  Vo = 16 V   Vo = 18 V 725, 10   670, 9.2 800, 9.9   730, 8.9 800, 8.8   770, 8.4  800, 4.1   900, 4.5  0.99, 0.98  12.5 AT 14 W 18 W	90 - 265 V  740, 10 830, 10 840, 9  840, 4.2  0.99, 0.98  12.5 AT 14 W 20 W	90 - 265 V  750, 10 800, 9.5 800, 8.5  800, 4  0.99, 0.98  12.5 AT 14 W 26 W
			35 V / 70 V	200 V / 400 V
<b>Efficiency</b> AC 230 V input, full load AC 115 V input, max. load	82 % 80 %	87 % 83 %	89 % 85 %	89 % 86 %
<b>Regulation</b>				
Load 0 - 100% <b>CV</b> Line 120 - 265 V AC <b>CV</b> (measured on sense block)	0.2 mV 0.2 mV	0.5 mV 0.2 mV	2 mV 0.5 mV	10 mV 2 mV
Load 0 - 100% <b>CC</b> Line 120 - 265 V AC <b>CC</b> (internal voltage sense)	4 mA 1 mA	3 mA 1 mA	1.5 mA 1 mA	0.5 mA 0.2 mA
<b>Ripple + noise</b> rms (BW=300 kHz) <b>CV</b> p-p (BW=20 MHz) <b>CV</b>  rms (BW=300 kHz) <b>CC</b> p-p (BW=20 MHz) <b>CC</b> <i>CC-ripple at full load</i>	2.5 mV 10 mV  25 mA 120 mA	2 mV 8 mV  5 mA 25 mA	3 mV 15 mV  3 / 1 mA 15 / 5 mA	15 mV 80 mV  0.8 / 0.5 mA 3 / 1.5 mA
<b>Front panel connection</b>	<b>Not available</b>	<b>Option 257</b>	<b>Option 258</b>	<b>Option 259</b>
Load Regulation: Load 0 - 100% <b>CV</b> Ripple + noise rms (BW=300 kHz) <b>CV</b> p-p (BW=20 MHz) <b>CV</b>	- - -	15 mV 3 mV 18 mV	40 mV 4 mV 20 mV	15 mV 18 mV 150 mV
<b>Temp. coeff., per °C</b> <b>CV</b> <b>CC</b>			35.10 <sup>-6</sup> 60.10 <sup>-6</sup>	
<b>Stability</b> after 1 hr warm-up during 8 hrs <b>CV</b> <b>CC</b>  t <sub>amb</sub> = 25 ± 1 °C, V <sub>in</sub> = 230 V AC (int. voltage sensing for CC-stab.)			6.10 <sup>-5</sup> 9.10 <sup>-5</sup>	
<b>Analog Programming</b>	<b>CV</b>		<b>CC</b>	
<b>Programming inputs</b> input range accuracy offset temp. coeff. offset input impedance	0 - 5 V ± 0.2% - 0.1 ... +1.3 mV (on 5V) 10 μV / °C > 1 MOhm		0 - 5 V ± 0.5% 0 ... +2.2 mV (on 5V) 50 μV / °C > 1 MOhm	
<b>Monitoring output</b> output range accuracy offset temp. coeff. offset output impedance	0 - 5 V ± 0.2% - 1... 0 mV (on 5V) 3 μV / °C 2 Ohm / max. 4 mA		0 - 5 V ± 0.5% - 1.1... 0 mV (on 5V) 60 μV / °C 2 Ohm / max. 4 mA	
<b>Reference voltage</b> on prog. connector V <sub>ref</sub> TC	5.114 V ± 15 mV (Ro = 2 Ohm, max. 4 mA) 20 ppm			
<b>+12 V output</b> on prog. Connector V <sub>o</sub> I <sub>max</sub> R <sub>o</sub>	12 V ± 0.2 V 0.2 A 3 Ohm			

<b>Relay Outputs</b> ACF DCF	AC - Fail DC - Fail <sup>1)</sup>	both NO and NC contact both NO and NC contact	<sup>1)</sup> output voltage $\pm 5\%$ beyond set point
<b>Status outputs</b> CC - status LIM - status OT - status PSOL - status ACF - status DCF - status	CC - operation CV- or CC-limit Over Temperature Power Sink Overload AC - Fail DC - Fail <sup>2)</sup>	5 V = logic 1 ( $R_o = 500 \text{ Ohm}$ ) 5 V = logic 1 ( $R_o = 500 \text{ Ohm}$ ) 5 V = logic 1 ( $R_o = 500 \text{ Ohm}$ ) 5 V = logic 1 ( $R_o = 500 \text{ Ohm}$ ) 5 V = logic 1 ( $R_o = 500 \text{ Ohm}$ ) 5 V = logic 1 ( $R_o = 500 \text{ Ohm}$ )	<sup>2)</sup> output voltage $\pm 5\%$ beyond set point
<b>Remote ShutDown</b>	with + 5V, 1 mA or relay contact		
<b>Interlock</b>	contact at rear panel, see photo of rear panel on page 1-6		
<b>Indicators</b> (front panel)	Voltage meter, Ampere meter, AC-Fail, DC-Fail, Over Temperature, Power Sink Overload, Remote-ShutDown, Remote-CV, Remote-CC, Output On, CV-limit, CC-limit, CV- and CC- mode		
<b>Controls</b> (front panel)	Mains on/off switch, CV-and CC-potmeter, CV- and CC-limit-potmeter, Display-Settings button, Display-Limits button, Remote/Local button, Output On/Off button, Front panel Lock buttons.		

<b>Programming speed</b> <i>Standard Version</i>	<b>SM 7.5-80</b>	<b>SM 18-50</b>	<b>SM 70-AR-24</b>	<b>SM 400-AR-4</b>
<b>Rise time (10 - 90%)</b> output voltage step time, (100 % load) time, (10 % load)	0 $\rightarrow$ 7.5 V 6.5 ms 2.5 ms	0 $\rightarrow$ 16 V 12 ms 5 ms	0 $\rightarrow$ 35 V 6 ms 2.5 ms	0 $\rightarrow$ 200 V 4 ms 2 ms
output voltage step time, (100 % load) time, (10 % load)	- - -	- - -	0 $\rightarrow$ 70 V 10 ms 7 ms	0 $\rightarrow$ 400 V 8 ms 5 ms
<b>Fall time (90 - 10%)</b> output voltage step time, (100 % load) time, (10 % load)	7.5 $\rightarrow$ 0 V 6.5 ms 62 ms	16 $\rightarrow$ 0 V 12 ms 120 ms	35 $\rightarrow$ 0 V 6 ms 60 ms	200 $\rightarrow$ 0 V 4 ms 42 ms
output voltage step time, (100 % load) time, (10 % load)	- - -	- - -	70 $\rightarrow$ 0 V 25 ms 250 ms	400 $\rightarrow$ 0 V 15 ms 155 ms
<b>Programming speed</b> <i>High speed Version</i>	<b>SM 7.5-80</b> <i>Option P250</i>	<b>SM 18-50</b> <i>Option P251</i>	<b>SM 70-AR-24</b> <i>Option P252</i>	<b>SM 400-AR-4</b> <i>Option P253</i>
<b>Rise time (10 - 90%)</b> output voltage step time, (100 % load) time, (10 % load)	0 $\rightarrow$ 7.5 V 0.2 ms 0.2 ms	0 $\rightarrow$ 16 V 0.22 ms 0.26 ms	0 $\rightarrow$ 35 V 0.24 ms 0.24 ms	0 $\rightarrow$ 200 V 0.4 ms 0.3 ms
output voltage step time, (100 % load) time, (10 % load)	- - -	- - -	0 $\rightarrow$ 70 V 0.24 ms 0.24 ms	0 $\rightarrow$ 400 V 0.82 ms 0.55 ms
<b>Fall time (90 - 10%)</b> output voltage step time, (100 % load) time, (10 % load)	7.5 $\rightarrow$ 0 V 0.2 ms 1 ms	16 $\rightarrow$ 0 V 0.24 ms 1.95 ms	35 $\rightarrow$ 0 V 0.27 ms 3 ms	200 $\rightarrow$ 0 V 0.42 ms 4.6 ms
output voltage step time, (100 % load) time, (10 % load)	- - -	- - -	70 $\rightarrow$ 0 V 0.85 ms 9.5 ms	400 $\rightarrow$ 0 V 1.7 ms 20 ms
<b>Ripple @ full load</b> (rms/pp) @ full load (rms/pp)	20 / 80 mV	40 / 120 mV	35 V / 24 A 25 / 90 mV 70 V / 12 A 30 / 110 mV	200 V / 4 A 35 / 200 mV 400 V / 2 A 30 / 160 mV
<b>Output capacitance</b>	310 $\mu\text{F}$	200 $\mu\text{F}$	80 $\mu\text{F}$	4 $\mu\text{F}$

*Notes: All specifications regarding programming speed are typical and measured on a resistive load.*

	<b>SM 7.5-80</b>	<b>SM 18-50</b>	<b>SM 70-AR-24</b>	<b>SM 400-AR-4</b>
<b>Recovery time</b> recovery within di/dt of load step output voltage time, @ 50 - 100% load step max. deviation @ 230 V AC input voltage	50 mV 1.25 A/ $\mu\text{s}$ 7 V 100 $\mu\text{s}$ 160 mV	60 mV 0.9 A/ $\mu\text{s}$ 15 V 100 $\mu\text{s}$ 150 mV	35 V / 70 V 75 mV 0.4 / 0.2 A/ $\mu\text{s}$ 30 / 65 V 100 $\mu\text{s}$ 250 / 200 mV	200 V / 400 V 1 / 0.5 V 0.1 / 0.05 A/ $\mu\text{s}$ 185 / 370 V 100 $\mu\text{s}$ 2 / 1.5 V
<b>Output impedance</b> CV, 0-1 kHz CV, 1-100 kHz	< 1 m $\Omega$ < 30 m $\Omega$	< 2 m $\Omega$ < 30 m $\Omega$	< 7 m $\Omega$ < 35 m $\Omega$	< 0.18 $\Omega$ < 2 $\Omega$
<b>Pulsating load</b> max. tolerable AC component of load current f > 1 kHz f < 1 kHz	15 Arms 80 Apeak	15 Arms 50 Apeak	10 Arms 12 / 24 Apeak	0.4 Arms 2 / 4 Apeak

<b>Insulation</b> input / output creepage / clearance	3750 Vrms (1 min.) 8 mm
input / case output / case	2500 Vrms 600 V DC
<b>Safety</b>	EN 60950 / EN 61010
<b>EMC Power Supply Standard</b>	<b>EN 61204-3</b> , Emission: residential, <b>light</b> industrial environment (CISPR22-Class <b>B</b> ) Immunity: industrial environment
<b>Generic Emission Generic Immunity</b>	<b>EN 61000-6-3</b> , residential, <b>light</b> industrial environment (EN 55022 <b>B</b> ) <b>EN 61000-6-2</b> , industrial environment
<b>Operating Temperature at full load</b>	- 20 to + 50 °C derate output to 75% at 60 °C
<b>Humidity</b>	max. 95% RH, non condensing, up to 40 °C max. 75% RH, non condensing, up to 50 °C
<b>Storage temperature</b>	- 40 to + 85 °C
<b>Thermal protection</b>	Output shuts down in case of insufficient cooling
<b>MTBF</b>	500 000 hrs

<b>Hold-Up time</b> V <sub>out</sub> = 100%, P <sub>out</sub> ≤ 840 W V <sub>out</sub> = 85%, I <sub>out</sub> = 100% V <sub>out</sub> = 100%, I <sub>out</sub> = 50% @ 230 V AC input	(time till DC-fail = 1)	16 ms 20 ms 36 ms
<b>Turn on delay</b> after mains switch on		600 ms @ 230 V AC, 900 ms @ 115 V AC
<b>Inrush current</b>		24 A @ 115 V AC, 22 A @ 230 V AC

<b>Series operation</b> max. total voltage Master / Slave operation		600 V yes		
<b>Parallel operation</b> max. total current Master / Slave operation		no limit max. 4 units (including master)		
<b>Remote sensing</b> max. volt. drop per load lead		2 V		
<b>Limits Voltage</b> adjust range <b>Current</b> adjust range		0 - 102% 0 - 102%		
<b>Potentiometers &amp; Encoders</b> front panel control with knobs resolution		standard 0.03 %		
screwdriver adjustment digital encoders		Option P001 (at front panel) Option P236		
	<b>SM 7.5-80</b>	<b>SM 18-50</b>	<b>SM 70-AR-24</b>	<b>SM 400-AR-4</b>
<b>Meters</b> scale voltage scale current accuracy read output read limit setting (d = digit)	3.5 digit 0 - 7.50 V 0 - 80.0 A 0.5% + 2 d 2% + 2 d	3.5 digit 0 - 18.00 V 0 - 50.0 A 0.5% + 2 d 2% + 2 d	3.5 digit 0 - 70.0 V 0 - 24.0 A 0.5% + 2 d 2% + 2 d	3.5 digit 0 - 400 V 0 - 4.00 A 0.5% + 2 d 2% + 2 d

<b>Mounting</b>	Stacking of units allowed, air flow is from rear to the sides.
<b>Input Connector</b>	IEC320/C14, EN 60320/C14
<b>Output Terminals</b>	M5 bolts
<b>Programming connector</b>	15 pole D-connector at rear panel (FEMALE)
<b>Cooling</b> audio noise level airflow	Low noise blower, fan speed adapts to temperature of internal heatsink. ca. 45 dBA at full load, 25 °C ambient temperature, 1 m distance ca. 50 dBA at full load, 50 °C ambient temperature, 1 m distance from rear to sides
<b>Enclosure</b> degree of protection	IP20
<b>Dimensions</b> behind front panel: h x w x d front panel: h x w	86 x 221 x 406 mm (feet removed) 88.1 x 222 mm (1/2 19", 2 U)
<b>Weight</b>	5.4 kg

## Typical Applications

- Accurate current sources
- Electronic circuit development
- Component device testing
- ATE in industrial production lines
- Automotive battery simulation
- Controlled battery (dis)charging
- Lasers
- Driving PWM-controlled DC-motors
- Medical research equipment
- Aerospace and military equipment

## Available Options



### Increased Output Power

The conservatively rated unit allows to deliver extra output with the same reliability.

At some derating, either the maximum output voltage or the maximum output current can be increased by about 10%.

- Order Code - P069



### High speed programming

A 10 to 20 times higher programming speed (down to 0.2 ms rise time at full load)

and lower output capacitance. Excellent for laser applications, test systems or as current source with low parallel capacitance as used in plasma chambers.

- Order Codes :  
SM 7.5-80 P250 - SM 70-AR-24 P252  
SM 18-50 P251 - SM 400-AR-4 P253



### Two-Quadrant Output: Power sink

Two quadrant operations maintains the output voltage constant regardless the

output power is positive or negative. Ideal for PWM-speed controlled DC-motors and ATE systems.

- Order Codes :  
SM 7.5-80 P245 - SM 70-AR-24 P247  
SM 18-50 P246 - SM 400-AR-4 P248

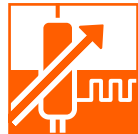

### Digital Voltage and current setting

Reliable, long life digital encoders are implemented at the front panel.

Includes total front panel lock (also for CV/CC-knobs) and a coarse or fine pitch adjustment depending on the turning speed.

- Order Code - P236



### Sequencer

Arbitrary Waveform generator or standalone automation.

The sequencer is integrated in the Ethernet controller.

- Order Code - P256



### Secured Voltage and Current Setting

For a maximum security, the CV/CC settings can be adjusted with a screwdriver only and are protected with a plastic cap from accidental adjusting.

- Order Code - P001



### Software control and interfaces

Factory installed programming interfaces:

- ISO AMP Card - isolated analog - P249
- RS232 controller - P254
- IEEE488 controller - P255
- Ethernet controller (incl. sequencer) - P256
- PROFIBUS controller - P271
- CANBUS controller - P272



### 19" Rack Mounting Adapter

The 19" mounting adapters makes it possible to position one or two units

side by side in a 19" rack.

- Order Code RA19 - 1SM800 (for 1unit)
- Order Code RA19 - 2SM800 (for 2 units)



### Front Power Output

Blind posts at the front panel instead of at the rear panel.

- Order Codes :  
SM 7.5-80 n.a. - SM 70-AR-24 P258  
SM 18-50 P257 - SM 400-AR-4 P259

Note: 1. Download datasheets about High Speed Programming, Power Sink and Battery Charging from [www.DeltaPowerSupplies.com](http://www.DeltaPowerSupplies.com).  
2. There is only room for one of the interfaces in a unit (P249, P254, P255, P256, P271 or P272).



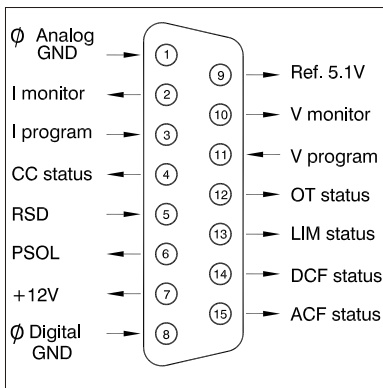
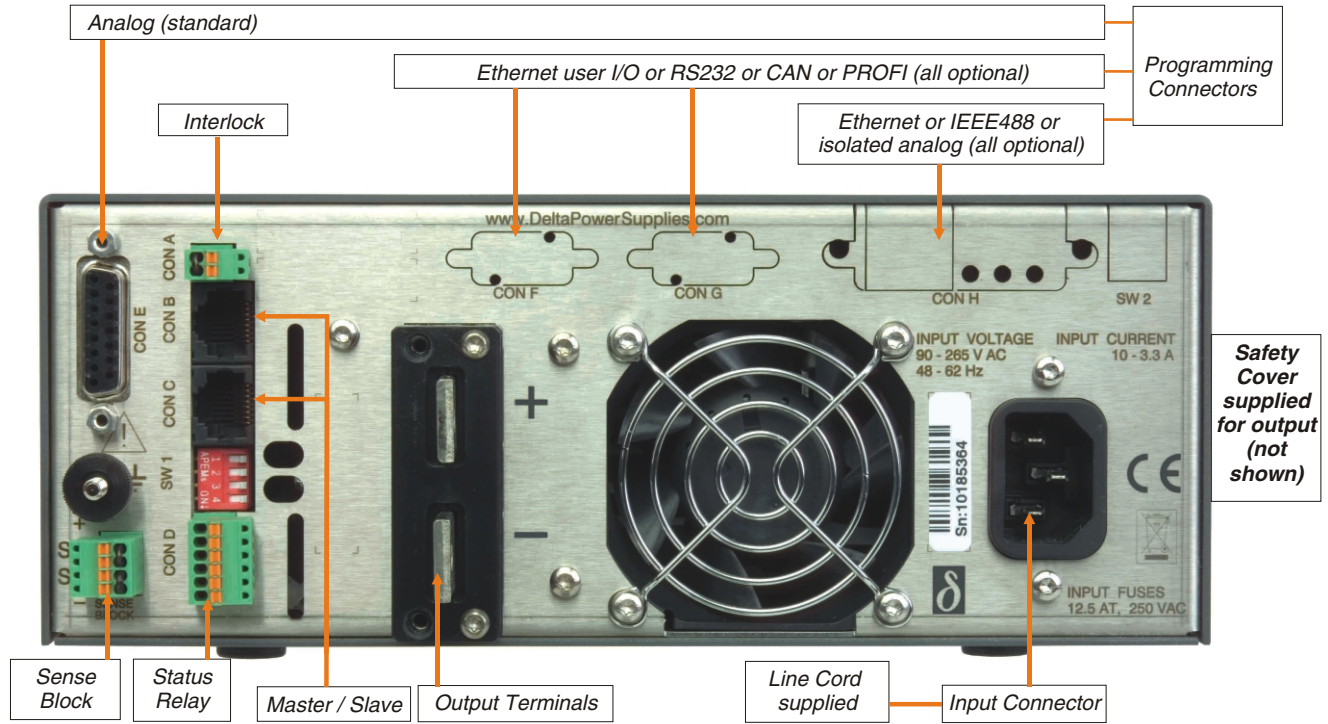

Connections programming connector

CV = Constant Voltage  
 CC = Constant Current

Specifications measured at  $t_{amb} = 25 \pm 5^\circ C$  and  $V_{in} = 230 V AC$ , 50 Hz, unless otherwise noted.

The information in this document is subject to change without notice

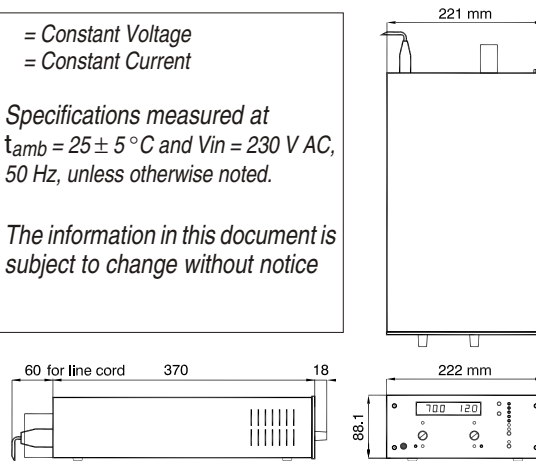

19" Rack Adapter RA19-2 SM800



Front panel connection  
 SM18-50 Opt. 257  
 SM70-AR-24 Opt. 258  
 SM400-AR-4 Opt. 259



19" Rack Adapter RA19-1 SM800