

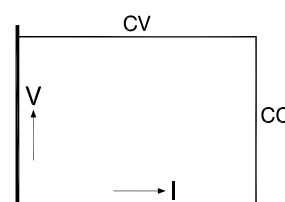

## SM 6000 - Series 6000 W DC POWER SUPPLIES

### Three phase input

Models	Voltage range	Current range
SM 15-400	0 - 15 V	0 - 400 A
SM 30-200	0 - 30 V	0 - 200 A
SM 45-140	0 - 45 V	0 - 140 A
SM 60-100	0 - 60 V	0 - 100 A
SM 70-90	0 - 70 V	0 - 90 A
SM 120-50	0 - 120 V	0 - 50 A
SM 300-20	0 - 300 V	0 - 20 A
SM 600-10	0 - 600 V	0 - 10 A



### Features

- cTUVus safety approval
- Designed for long life at full power
- Excellent dynamic response to load changes
- Protected against all overload and short circuit conditions
- EMC surpasses CE requirements: low emission & high immunity
- Low audible noise: temperature controlled fans
- Available options: analog & digital Interfaces, High Speed Programming, Digital Encoders, Sequencer, Power Sink etc.

### Functionalities

- Master/Slave parallel and series operation with voltage and current sharing
- Stacking is allowed, space between units is not required
- High power system configuration from multiple units
- 19" rack mounting or laboratory use (feet included)
- Remote sensing
- Interlock

	SM 15-400	SM 30-200	SM 45-140	SM 60-100	SM 70-90	SM 120-50	SM 300-20	SM600-10
<b>Output</b> voltage current	0 - 15 V 0 - 400 A	0 - 30 V 0 - 200 A	0 - 45 V 0 - 140 A	0 - 60 V 0 - 100 A	0 - 70 V 0 - 90 A	0 - 120 V 0 - 50 A	0 - 300 V 0 - 20 A	0-600 V 0-10 A
<b>Input</b> AC 3 phase, 48 - 62 Hz rated voltage range rated frequency rated current	342 - 528V 380 - 480V 50 / 60 Hz Max. 12.2A	342 - 528V 380 - 480V 50 / 60 Hz Max. 12.2A	342 - 528V 380 - 480V 50 / 60 Hz Max. 12.2A	342 - 528V 380 - 480V 50 / 60 Hz Max. 12.2A	342 - 528V 380 - 480V 50 / 60 Hz Max. 12.2A	342 - 528V 380 - 480V 50 / 60 Hz Max. 12.2A	342 - 528V 380 - 480V 50 / 60 Hz Max. 12.2A	342 - 528V 380 - 480V 50 / 60 Hz Max. 12.2A
current (400 V / 3 ph, full load) power factor, 100%, 50% load	10.2 A 0.98, 0.97	10 A 0.98, 0.97	10.3 A 0.98, 0.97	10 A 0.98, 0.97	10.4 A 0.98, 0.97	9.9 A 0.98, 0.97	10 A 0.98, 0.97	10 A 0.98, 0.97
internal fuses standby input power ( $V_o=I_o=0$ ) standby input power ( $V_o=V_{max}$ )	15 AT 55 W 110 W	15 AT 55 W 110 W	15 AT 55 W 110 W	15 AT 55 W 110 W	15 AT 55 W 130 W	15 AT 55 W 130 W	15 AT 55 W 120 W	15 AT 55 W 130 W
<b>Efficiency</b> 400 V AC, 3 ph input, full load	87 %	89 %	90 %	89 %	89 %	89 %	89 %	89 %
<b>Regulation</b>								
Load 0 - 100% Line 342 - 457 V AC (external voltage sense)	<b>CV</b> <b>CV</b> 2.5 mV 0.2 mV	5 mV 0.5 mV	5 mV 1 mV	5 mV 2 mV	5 mV 2 mV	8 mV 2 mV	15 mV 3 mV	20 mV 4 mV
Load 0 - 100% Line 342 - 457 V AC (internal voltage sense, after warm-up)	<b>CC</b> <b>CC</b> 24 mA 4 mA	12 mA 2 mA	9 mA 1.5 mA	6 mA 1 mA	5 mA 1 mA	3 mA 0.5 mA	1.2 mA 0.2 mA	1.0 mA 0.2 mA
<b>Ripple + noise</b>								
rms (BW=300 kHz) p-p (BW=20 MHz)	<b>CV</b> <b>CV</b> 0.8 mV 8 mV	1 mV 8 mV	1.5 mV 10 mV	2 mV 10 mV	2 mV 10 mV	3 mV 25 mV (20 mV @ full load)	5 mV 50 mV (30 mV @ full load)	10 mV 100 mV (80 mV @ full load)
rms (BW=300 kHz) p-p (BW=20 MHz) CC-ripple at full load	<b>CC</b> <b>CC</b> 100 mA 300 mA	20 mA 60 mA	8 mA 25 mA	3 mA 10 mA	3 mA 10 mA	3 mA 10 mA	2 mA 5 mA	2 mA 5 mA
<b>Temp. coeff., per °C</b>	<b>CV</b> <b>CC</b>							
<b>Stability</b> after 1 hr warm-up during 8 hrs	<b>CV</b> <b>CC</b>							
$t_{amb} = 25 \pm 1 \text{ °C}$ , $V_{in} = 400 \text{ V AC}$ internal voltage sensing for CC-stab.								

<b>Analog Programming</b> <i>Note: for SM300-20 / SM600-10 see ISO AMP</i>	<b>CV</b>	<b>CC</b>
<b>Programming inputs</b> input range accuracy offset temp. coeff. offset input impedance	0 - 5 V $\pm 0.2\%$ - 0.1 ... +1.3 mV (on 5V) 10 $\mu\text{V} / \text{°C}$ > 1 MOhm	0 - 5 V $\pm 0.5\%$ 0 ... +2.2 mV (on 5V) 50 $\mu\text{V} / \text{°C}$ > 1 MOhm
<b>Monitoring outputs</b> output range accuracy offset temp. coeff. offset output impedance	0 - 5 V $\pm 0.2\%$ - 1... 0 mV (on 5V) 3 $\mu\text{V} / \text{°C}$ 2 Ohm / max. 4 mA	0 - 5 V $\pm 0.5\%$ - 1.1 ... 0 mV (on 5V) 60 $\mu\text{V} / \text{°C}$ 2 Ohm / max. 4 mA
<b>ISO AMP Programming</b> <i>optional for low volt. units up to 120V (P154), standard on SM300-20 and SM600-10.</i>	Isolated analog programming, range 0 - 5 V / 200 kOhm or 0 - 10 V / 400 kOhm. See datasheet ISO AMP on <a href="http://www.DeltaPowerSupplies.com">www.DeltaPowerSupplies.com</a> for accuracy, offset etc.	

<b>Reference voltage</b> on prog. connector	$V_{ref}$ TC	5.114 $\pm$ 15 mV ( $R_o = 2 \text{ Ohm}$ , max. 4 mA) 20 ppm / °C
<b>+12 V output</b> on prog. Connector	$V_o$ $I_{max}$ $R_o$	12 V $\pm$ 0.2 V 0.2 A 3 Ohm

<b>Status outputs</b>	CC - status LIM - status OT - status PSOL - status ACF - status DCF - status	CC - operation CV or CC limit Over Temperature Power Sink Overload AC - Fail DC - Fail <sup>1)</sup>	5 V = logic 1 (R <sub>o</sub> = 500 Ohm) 5 V = logic 1 (R <sub>o</sub> = 500 Ohm) 5 V = logic 1 (R <sub>o</sub> = 500 Ohm) 5 V = logic 1 (R <sub>o</sub> = 500 Ohm) 5 V = logic 1 (R <sub>o</sub> = 500 Ohm) 5 V = logic 1 (R <sub>o</sub> = 500 Ohm)
<b>Relay Outputs</b>	ACF DCF	AC - Fail DC - Fail <sup>1)</sup>	both NO and NC contact both NO and NC contact <sup>1)</sup> output ± 5% beyond set point
<b>Remote ShutDown</b>	with + 5V, 1 mA or relay contact		
<b>Interlock</b>	contact at rear panel, see photo of rear panel on page 1-6		
<b>Indicators</b> (front panel)	AC-Fail, DC-Fail, Over Temperature, Power Sink Overload, Remote-ShutDown, Remote-CV, Remote-CC, Output On, CV-limit, CC-limit, CV- and CC- mode		
<b>Controls</b> (front panel)	Mains on/off, CV-and CC-potmeter, CV- and CC-limit-potmeter, Display-Settings button, Display-Limits button, Remote/Local, Output On/Off, Front panel Lock		

<b>Programming speed</b> <i>Standard Version</i> (resistive load)	<b>SM 15-400</b>	<b>SM 30-200</b>	<b>SM 45-140</b>	<b>SM 60-100</b>	<b>SM 70-90</b>	<b>SM 120-50</b>	<b>SM 300-20</b>	<b>SM 600-10</b>
<b>Rise time (10 - 90%)</b> output voltage step time, (100 % load) time, (10 % load)	0 → 15 V 3.3 ms 1.3 ms	0 → 30 V 6.4 ms 2.5 ms	0 → 45 V 2.7 ms 1.1 ms	0 → 60 V 5.4 ms 2.2 ms	0 → 70 V 6.8 ms 2.8 ms	0 → 120 V 5.1 ms 1.9 ms	0 → 300 V 8.5 ms 3.2 ms	0 → 600 V 12 ms 4.8 ms
<b>Fall time (90 - 10%)</b> output voltage step time, (100 % load) time, (10 % load)	15 → 0 V 3.5 ms 34 ms	30 → 0 V 6.7 ms 67 ms	45 → 0 V 2.9 ms 32 ms	60 → 0 V 5.8 ms 59 ms	70 → 0 V 7.7 ms 77 ms	120 → 0 V 4.9 ms 52 ms	300 → 0 V 8.3 ms 83 ms	600 → 0 V 12 ms 120 ms
<b>Programming speed</b> <i>High Speed Version</i> (resistive load)	<b>SM 15-400</b> <i>Option P166</i>	<b>SM 30-200</b> <i>Option P167</i>	<b>SM 45-140</b> <i>Option P168</i>	<b>SM 60-100</b> <i>Option P169</i>	<b>SM 70-90</b> <i>Option P170</i>	<b>SM 120-50</b> <i>Option P171</i>	<b>SM 300-20</b> <i>Option P172</i>	<b>SM 600-10</b> <i>Option P270</i>
<b>Rise time (10 - 90%)</b> output voltage step time, (100 % load) time, (10 % load)	0 → 15 V 0.40 ms 0.38 ms	0 → 30 V 0.41 ms 0.38 ms	0 → 45 V 0.53 ms 0.16 ms	0 → 60 V 0.44 ms 0.41 ms	0 → 70 V 0.62 ms 0.40 ms	0 → 120 V 0.57 ms 0.19 ms	0 → 300 V 1.1 ms 0.44 ms	0 → 600 V 1.9 ms 0.80 ms
<b>Fall time (90 - 10%)</b> output voltage step time, (100 % load) time, (10 % load)	15 → 0 V 0.39 ms 1.5 ms	30 → 0 V 0.41 ms 3.6 ms	45 → 0 V 0.26 ms 10 ms	60 → 0 V 0.57 ms 5.6 ms	70 → 0 V 0.50 ms 6.2 ms	120 → 0 V 0.38 ms 4.2 ms	300 → 0 V 1.0 ms 10 ms	600 → 0 V 2.2 ms 20 ms
<b>Ripple</b> @ full load typical (rms / pp)	6/20mV	28/80mV	34/80mV	34/90mV	38/100mV	30/120mV	48/150mV	35/220mV
<b>Output Capacitance</b> (typical)	1200 µF	800 µF	520 µF	330 µF	290 µF	73 µF	32 µF	19 µF

	<b>SM 15-400</b>	<b>SM 30-200</b>	<b>SM 45-140</b>	<b>SM 60-100</b>	<b>SM 70-90</b>	<b>SM 120-50</b>	<b>SM 300-20</b>	<b>SM 600-10</b>
<b>Recovery time</b> recovery within di/dt of load step output voltage time, @ 50 - 100% load step max. deviation	60 mV 5 A/µs 13 V 120 µs 320 mV	50 mV 2.5 A/µs 25 V 100 µs 260 mV	100 mV 1.8 A/µs 40 V 100 µs 380 mV	100 mV 1.3 A/µs 55 V 100 µs 250 mV	100 mV 1.7 A/µs 65 V 100 µs 280 mV	0.5 V 1 A/µs 110 V 100 µs 1 V	1 V 0.25 A/µs 280 V 100 µs 1.8 V	1 V 0.125 A/µs 560 V 100 µs 1.8 V
<b>Output impedance</b> CV, 0-1 kHz CV, 1-100 kHz	< 0.5 mΩ < 2.3 mΩ	< 1.2 mΩ < 5 mΩ	< 1.7 mΩ < 10 mΩ	< 1.5 mΩ < 12 mΩ	< 1.8 mΩ < 12 mΩ	< 11 mΩ < 90 mΩ	< 34 mΩ < 330 mΩ	< 70 mΩ < 700 mΩ
<b>Pulsating load</b> max. tolerable AC component of load current f > 1 kHz f < 1 kHz	30 Arms 400 Apeak	35 Arms 200 Apeak	20 Arms 140 Apeak	20 Arms 100 Apeak	20 Arms 90 Apeak	10 Arms 50 Apeak	5 Arms 20 Apeak	2.5 Arms 10 Apeak

<b>Insulation</b> input / output creepage / clearance input / case output / case	3750 Vrms (1 min.) 8 mm 2500 Vrms 600 V DC (1200 V DC for SM300-20 and SM600-10)
<b>Safety</b>	cTUVus / EN 60950 / EN 61010

<b>EMC</b>	<b>Power Supply Standard</b>	<b>EN 61204-3</b> , Emission: residential, <b>light</b> industrial environment (CISPR22-Class <b>B</b> ) Immunity: industrial environment
	<b>Generic Emission</b> <b>Generic Immunity</b>	<b>EN 61000-6-3</b> , residential, <b>light</b> industrial environment (EN 55022 <b>B</b> ) <b>EN 61000-6-2</b> , industrial environment
<b>Operating Temperature at full load</b>		- 20 to + 50 °C derate output to 75% at 60 °C
<b>Humidity</b>		max. 95% RH, non condensing, up to 40 °C max. 75% RH, non condensing, up to 50 °C
<b>Storage temperature</b>		- 40 to + 85 °C
<b>Thermal protection</b>		Output shuts down in case of insufficient cooling
<b>MTBF</b>		500 000 hrs

	SM 15-400	SM 30-200	SM 45-140	SM 60-100	SM 70-90	SM 120-50	SM 300-20	SM 600-10
<b>Hold-Up time</b> $V_{out} = 100\%$ , $I_{out} = 100\%$ $V_{out} = 85\%$ , $I_{out} = 100\%$ $V_{out} = 100\%$ , $I_{out} = 50\%$ @ 400 V AC input	11 ms 23 ms 33 ms	11 ms 23 ms 28 ms	11 ms 23 ms 27 ms	11 ms 24 ms 28 ms	13 ms 23 ms 30 ms	13 ms 24 ms 32 ms	12 ms 24 ms 28 ms	11 ms 23 ms 27 ms
<b>Turn on delay</b> after mains switch on	200 ms							
<b>Inrush current</b>	20 A (electronic limit)							
<b>Phase loss</b>	Output shuts down in case of phase loss							

<b>Series operation</b> max. total voltage Master / Slave operation	600 V yes	600 V yes	600 V yes	600 V yes	600 V yes	600 V yes	1200 V yes	1200V yes
<b>Parallel operation</b> Normal Master / Slave operation	no limit max. 3 units							
<b>Remote sensing</b> max. voltage drop per load lead	2 V							
<b>Limits</b> <b>Voltage</b> adjust range <b>Current</b> adjust range	0 - 102% 0 - 102%							
<b>Front panel CV/CC-controls</b> resolution knob operation screwdriver adjustment  Lock function for CV/CC-settings Selectable Start-up at 0V / 0A or at last settings	analog potentiometers <sup>1)</sup> 10 turns (0.03%) standard optional (P001)  no no  <sup>1)</sup> optional with digital encoders (P220) : specifications for controls are similar to SM300-20 and SM600-10.						digital encoders 10 or 64 turns <sup>2)</sup> standard no  yes yes  <sup>2)</sup> variable pitch depending on operation speed	
<b>Meters</b> scale    voltage scale    current accuracy read output read limit setting (d = digit)	3.5 digit 0 - 15.00 V 0 - 400 A 0.5% + 2 d 2% + 2 d	3.5 digit 0 - 30.0 V 0 - 200 A 0.5% + 2 d 2% + 2 d	3.5 digit 0 - 45.0 V 0 - 140.0 A 0.5% + 2 d 2% + 2 d	3.5 digit 0 - 60.0 V 0 - 100.0 A 0.5% + 2 d 2% + 2 d	3.5 digit 0 - 70.0 V 0 - 90.0 A 0.5% + 2 d 2% + 2 d	3.5 digit 0 - 120.0 V 0 - 50.0 A 0.5% + 2 d 2% + 2 d	3.5 digit 0 - 300 V 0 - 20.0 A 0.5% + 2 d 2% + 2 d	3.5 digit 0 - 600 V 0 - 10.0 A 0.5% + 2 d 2% + 2 d

<b>Mounting</b>	Stacking of units allowed, air flow is from left to right.							
<b>Input Terminals</b>	Screw Terminals for cable 2.5 - 4 mm <sup>2</sup> , 3 phase + earth (no neutral required)							
<b>Output Terminals</b>	M12 bolts	M10 bolts	M10 bolts	M10 bolts	M10 bolts	M8 bolts	M8 bolts	M8 bolts
<b>Programming connector</b>	15 pole D-connector at rear panel (FEMALE)							
<b>Cooling</b> audio noise level  airflow	Low noise blower, fan speed adapts to temperature of internal heatsink. ca. 56 dBA at full load, 25 °C ambient temperature, 1 m distance ca. 62 dBA at full load, 50 °C ambient temperature, 1 m distance From left to right							
<b>Enclosure</b> degree of protection	IP20							
<b>Dimensions</b> behind front panel: h x w x d front panel: h x w	177 x 443 x 500 mm 177 x 483 mm (19", 4 U)							
<b>Weight</b>	27 kg							

## Typical Applications

- Solar inverter testing, PV-Simulation
- Controlled Battery (dis)charging
- Plasma chambers
- Lasers
- Hybrid Car test systems
- Driving PWM-Controlled DC motors
- ATE in industrial production lines
- Accurate current sources
- Automotive battery simulations
- Aerospace and military equipment

## Available Options



### Increased Output Power

The conservatively rated unit allows to deliver extra output with the same reliability.

At some derating, either the maximum output voltage or the maximum output current can be increased by about 10%.

- Order Code - P069



### High Speed Programming

A 10 to 20 times higher programming speed (down to 0.4 ms rise time at full load)

and lower output capacitance <sup>1)</sup>. Excellent for laser applications, test systems or as current source with low parallel capacitance as used in plasma chambers.

- Order Codes:  
SM 15-400 P166 - SM 30-200 P167  
SM 45-140 P168 - SM 60-100 P169  
SM 70-90 P170 - SM 120-50 P171  
SM 300-20 P172 - SM 600-10 P270



### Two-Quadrant Output: Power sink

Two quadrant operations maintains the output voltage constant

regardless the output power is positive or negative <sup>1)</sup>. Ideal for PWM-speed controlled DC-motors and ATE systems.

- Order Codes:  
SM 15-400 P230 - SM 30-200 P231  
SM 45-140 P232 - SM 60-100 P233  
SM 70-90 P234



### Sequencer

Arbitrary Waveform generator or standalone automation. The sequencer is integrated in the Ethernet controller.

- Order Code - P157



### Digital Voltage and Current Setting

Reliable, longlife digital encoders can be implemented at the front panel.

Includes total front panel lock (also for CV/CC-knobs) and a coarse or fine pitch adjustment depending on the turning speed. Is standard on SM300-20 and SM600-10.

- Order Code - P220



### Secured Voltage and Current Setting

For maximum security, the CV/CC settings can be adjusted with a screwdriver

only and are protected with a plastic cap from accidental adjusting. SM300-20, SM600-10 and units with option P220 already have secured settings.

- Order Code - P001



### Software control and Interfaces

Factory installed programming interfaces <sup>2)</sup>:

- ISO AMP Card - isolated analog - P154 <sup>3)</sup>
- RS232 controller - P155
- IEEE488 controller - P156
- Ethernet contr. (incl. sequencer) - P157
- PROFIBUS controller - P277
- CANBUS controller - P278



### High Input Voltage

All units standard have a rated input voltage range of 380...480 V AC.

Option P165 has become obsolete.

For older units, the nominal input voltage was 440 V AC, and option P165 was needed for operation at 480 V AC (check rear panel).

Notes: 1. Download datasheets about High Speed Programming, Power Sink and Battery Charging from [www.DeltaPowerSupplies.com](http://www.DeltaPowerSupplies.com).  
2. There is only room for one of the interfaces in a unit (P154, P155, P156, P157, P277 or P278).  
3. SM300-20, SM 600-10 are standard equipped with ISO AMP, this can be replaced by P155 or P156.  
These units are without non-isolated analog programming and cannot be combined with P157, P277 or P278.



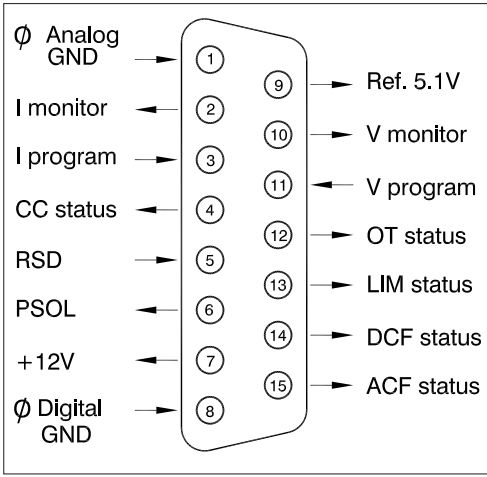

Connections analog programming connector

CV= Constant Voltage  
 CC= Constant Current

Specifications measured at  
 $t_{amb} = 25 \pm 5^\circ C$  and  $V_{in} = 400 V AC, 50 Hz, 3 phase$ , unless otherwise noted.

The information in this document is subject to change without notice

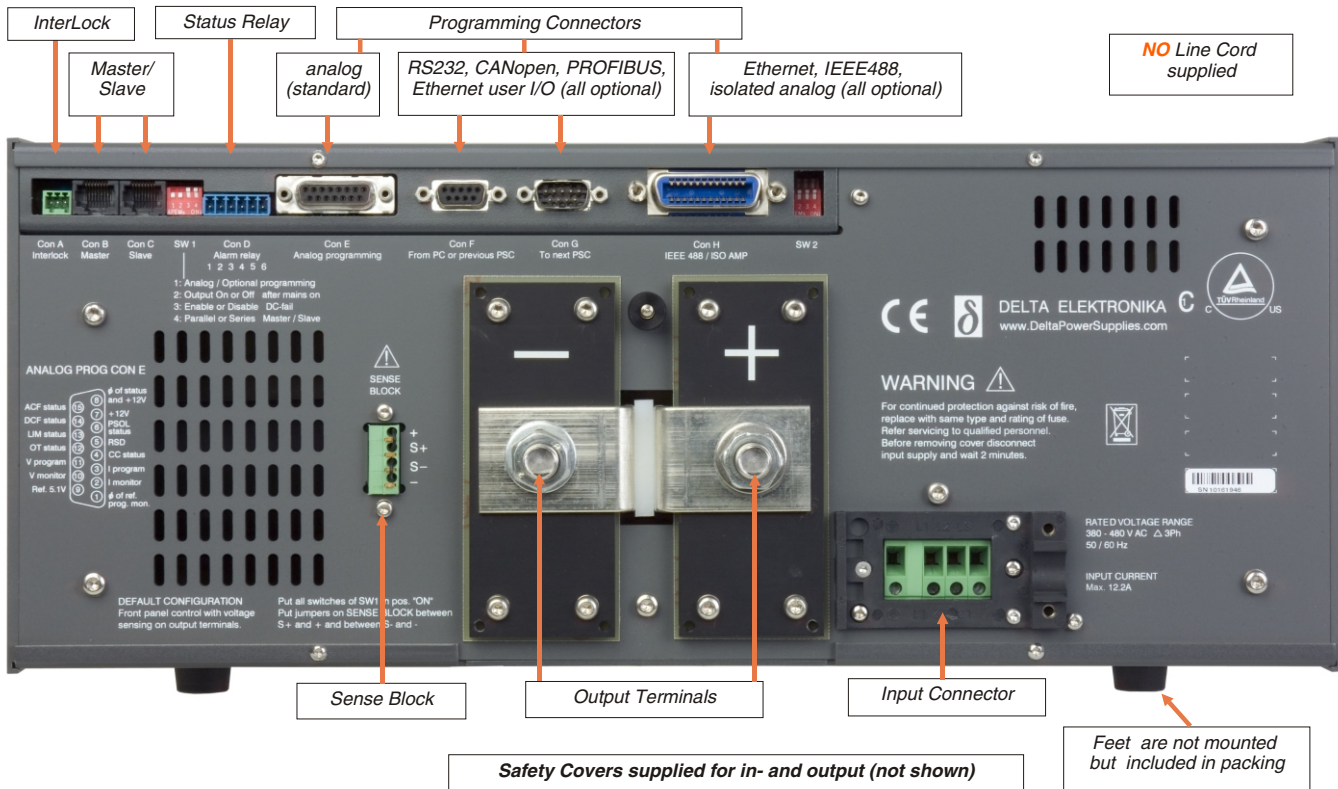
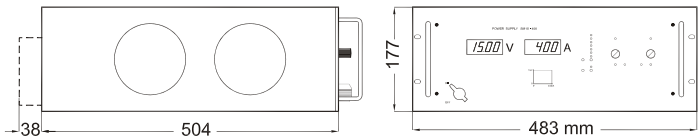

Sense Block, Output Terminals, Input Connector, Safety Covers supplied for in- and output (not shown), Feet are not mounted but included in packing

Note: SM300-20, SM 600-10 are standard equipped with isolated analog programming via ISO AMP on CON H (CON E is not available).

