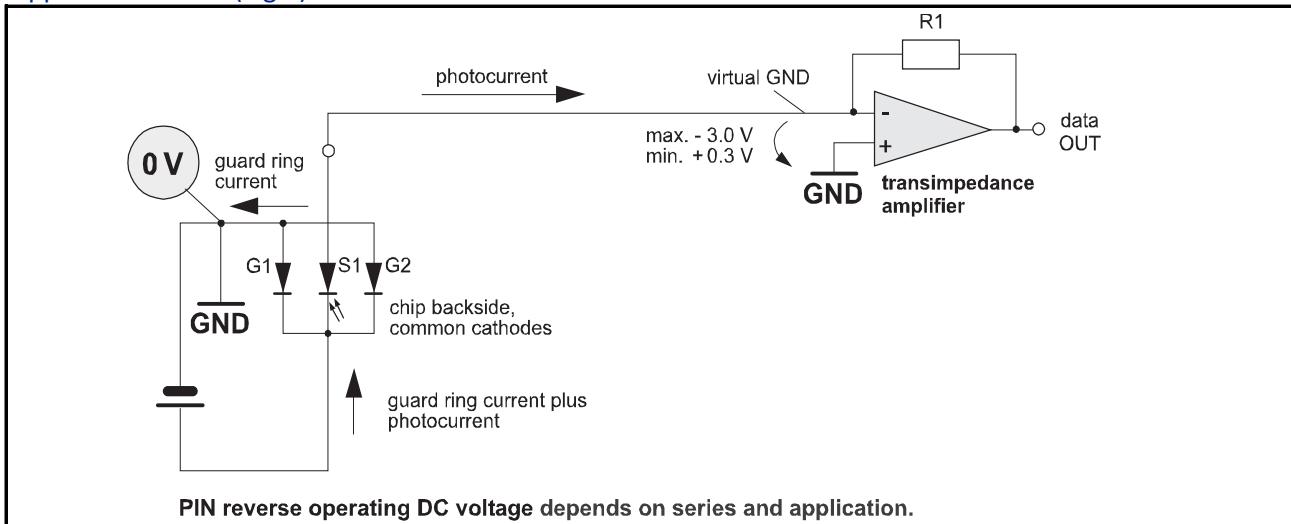

Application circuit (Fig.1)

Application notes

- Keep all cathodes including guard rings on virtual or real ground potential [GND = 0 V].
- A single diode cathode (including guard ring) must never float or get disconnected from GND potential.
- The maximum voltage difference between any diode cathode and GND is +3 V / -0.3 V
- The photocurrent must be allowed to flow from or to any virtual or real ground at any time. So the DC input resistance of the amplifier must not be giga-ohmic (as MOS inputs usually are).
- If there is more than one photodiode enclosed with a guard diode a single channel input per pixel is the best way to process the output data. Alternately, an analog switch may be used. The switch matrix must make sure that all pixels including the guard diode except for the actual measured one are connected to GND.
- The use of a secure current limiter in the reverse operating DC voltage line is recommended. Any overload may produce heat in the device and / or irreversible breakdown in the input structures of the transimpedance amplifiers or analog switches.☒
- Fig. 1 shows a sample circuit including the signal delivering diode S1 and the guard ring diodes G1 and G2. The guard ring diodes G1 and G2 are connected together on chip. Quadrant devices have 4 signal delivery diodes S1 to S4 and one surrounding guard ring diode instead of the two guard ring diodes G1 and G2 drawn in Fig. 1. The operation mode however is exactly the same as in arrays.☒
- The guard ring diode must be connected to the circuit at least once per device.
- The outer light shield metal is at backside potential and may be bonded to backside potential. If this connection is used instead of a true low resistive backside contact, there may be enhanced parasitic resistances in the signal path, depending on the chip size.
- Please note the gap regions in all avalanche array type devices including quadrants are insensitive to light.☒
- If a guard ring diode is present it must be connected to the circuit at least once per device. Multiple connections to the same potential are possible.☒
- The outer light shield metal is at backside potential and may be bonded to backside potential. If this connection is used instead of a true low resistive backside contact, there may be enhanced parasitic resistances in the signal path, depending on the chip size.
- Current should be limited by a protecting resistor or current limiting - IC inside the power supply.
- For low light level applications blocking of ambient light should be used.
- Use low noise read-out - IC.
- Optimized PIN power supplies and evaluation kits are available. Visit our website.
- For further questions please refer to document "Instructions for handling and processing".

European, International Sales:

First Sensor AG
 Peter-Behrens-Strasse 15
 12459 Berlin
 Germany
 T +49 30 6399 2399
 F +49 30 639923-752
 sales.opto@first-sensor.com

USA:



First Sensor Inc.
 5700 Corsa Avenue #105
 Westlake Village
 CA 91362 USA
 T +1 818 706 3400
 F +1 818 889 7053
 sales.us@first-sensor.com

PIN Series overview

PIN Series	Optimized for	Application	Special features
Series -2*	200...500 nm	Analytical instruments, readout for scintillators	UV/ blue enhanced
Series -6b	400...650 nm	Photometric illuminometer	Blue / green enhanced
Series -5b	360...550 nm	Optical fiber communication, high speed photometry	High-Speed Epitaxy, blue / green enhanced
Series -5t	400...850 nm		High-Speed Epitaxy, low voltage (3.5V)
Series -5t	450...950 nm		High-Speed Epitaxy
Series -6	700...950 nm	Precision photometry, analytical instruments	General purpose, low dark current, fast response
Series -7	700...1000 nm	High energy physics	Low capacity, full depletable
Series -Q	900...1100 nm	YAG laser detection	Enhanced NIR sensitivity, low voltage, fully depletable, low
Series -i	600...1700 nm	Eye-safe laser detection	InGaAs photodiodes, high IR sensitivity, low dark current
Series -X	Ionizing radiation	Medical, security, material	With or without scintillator, ultra

* Please note that Series -2 has opposite polarity w.r.t. the the other series'.

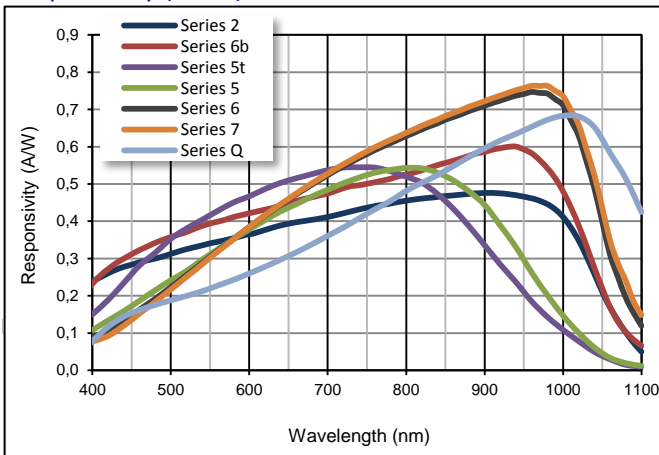
Responsivity (23 °C)



Quantum efficiency (23 °C)

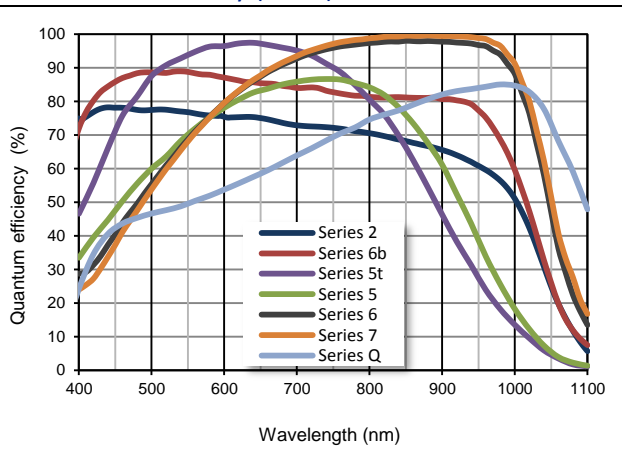

PIN part description

From the part description it is possible to conclude the basic geometry of the detector:

Number	Two letter designator : device type	Number	-	Number	Package desgnator
-	PC - PIN photodiode, circular area	Active area [mm ²]	-	Series	TO/THD/SMD/CLP/CH*
-	PS - PIN photodiode, square area	Active area [mm ²]	-	Series	TO/THD/SMD/CLP/CH*
-	PR - PIN photodiode, rectangular area	Active area [mm ²]	-	Series	TO/THD/SMD/CLP/CH*
-	DP - Dual PIN photodiode / bicell	Total active area [mm ²]	-	Series	TO/THD/SMD/CLP/CH*
-	QP - Quadrant photodiode	Total active area [mm ²]	-	Series	TO/THD/SMD/CLP/CH*
-	X - Ionizing raditaion detector	Active area [mm ²]	-	Series	TO/THD/SMD/CLP/CH*
Pixel count	XA - PIN PD array for ionizing radiation	Single pixel area [mm ²]	-	Series	TO/THD/SMD/CLP/CH*
Pixel count	PA - PIN photodiode array	Single pixel area [mm ²]	-	Series	TO/THD/SMD/CLP/CH*
Pixel count	IA - Irregular array	Single pixel area [mm ²]	-	Series	TO/THD/SMD/CLP/CH*

*Package designator:	TO	Metal can type package	BNC	BNC Connector (RF coaxial cable jack)
	THD	Through hole device package	CLP	Chip level package
	SMD	Surface mount device package	CH	Chip: bare die

Disclaimer: Due to our strive for continuous improvement, specifications are subject to change within our PCN policy according to JESD46C.

European, International Sales:



First Sensor AG
Peter-Behrens-Strasse 15
12459 Berlin
Germany
T +49 30 6399 2399
F +49 30 639923-752
sales.opto@first-sensor.com

USA:



First Sensor Inc.
5700 Corsa Avenue #105
Westlake Village
CA 91362 USA
T +1 818 706 3400
F +1 818 889 7053
sales.us@first-sensor.com