

ORCA[®]-Flash4.0 V2

Digital CMOS camera C11440-22CU

Discover the Breakthrough

Scientific breakthroughs rarely come from giant steps. Rather, it's a continuous progression of small steps and astute application of those differences that enables advances. The ORCA-Flash4.0 V2 is the perfect examples of this process. From its introduction the ORCA-Flash4.0 has challenged the status quo of imaging and undergone a series of useful enhancements. The most recent is perhaps the most exciting; a notable increase in the ability to detect photons. This enhanced QE means that you have a possibility of detecting the faintest of signals. Or, for moderately dim samples, that the ideal image is achievable with shorter exposure times, perhaps saving your cells from phototoxicity or bleaching. With the ORCA-Flash4.0 V2 already delivering wide field of view, large dynamic range, and fast frame rates, this QE enhancement only makes it more versatile and powerful.

If you have not yet experienced the ORCA-Flash4.0 V2 sCMOS, now is the time. What breakthrough will you make with your extra photons?

Exceptional quantum efficiency

82% (Peak QE)

Available Now

Low noise

1.0 electrons median **1.6** electrons rms
Standard scan at 100 frames/s

0.8 electrons median **1.4** electrons rms
Slow scan at 30 frames/s

High-speed readout

100 frames/s
Camera Link at 4.0 megapixels



HAMAMATSU
PHOTON IS OUR BUSINESS

Key Features in the ORCA-Flash4.0 V2

● Enhanced Quantum Efficiency

The QE is the wavelength dependent probability that a photon is converted to a photoelectron. The enhanced QE of the ORCA-Flash4.0 V2 is 82 % peak QE.

● Two Scan Speeds

While the read noise at standard scan is only 1.6 electrons rms (1.0 electrons median), there are some experiments for which even lower noise is more important than raw speed. The ORCA-Flash4.0 V2 is an additional slow scan readout mode with read noise of just 1.4 electrons rms (0.8 electrons median). Both the USB and Camera Link configurations of the camera have this low noise capability.

● Lightsheet Readout Mode (Patent pending)

To enable the best speeds and synchronization for light sheet microscopy, the ORCA-Flash4.0 V2 configured with the Camera Link interface can be read out in one sweep across the sensor from top to bottom or bottom to top using our new Lightsheet Readout Mode.

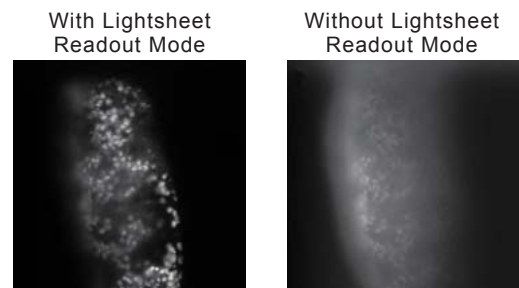

Courtesy of Dr. Hufnagel and Dr. Krzic, EMBL Heidelberg, Germany

● Global Exposure Flexibility

By adding a Global Reset function to the ORCA-Flash4.0 V2, users can acquire global exposures and choose to have either an external source or the camera be master of the timing.

● Individualized Documentation

Knowing as much as possible about your camera helps increase confidence in the results it produces - especially under demanding experimental conditions. Every ORCA-Flash4.0 V2 is individually characterized at the factory before it ships, and the results of these tests are included with each camera. A measured noise histogram, photon transfer curve, rms noise value and conversion factor (electron/count) are provided along with simple formulas to make use of this information. Next time you're asked how many photons were detected you'll know the answer!

→ Applications

The ORCA-Flash4.0 V2 is ideally suited for fluorescence and other widefield microscopy applications.

- Super-resolution microscopy
- TIRF microscopy
- Ratio imaging
- FRET
- High-speed Ca^{2+} imaging
- Real-time confocal microscopy
- Light sheet microscopy

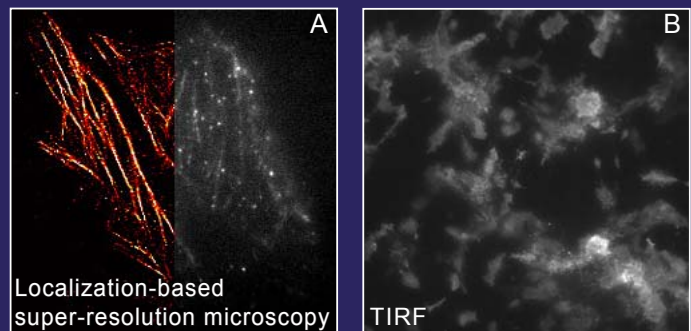

A HeLa cells labeled with d2EosFP. Left: reconstructed image. Right: single TIRF image from data used for reconstruction. (Images courtesy of Prof. Zhen-li Huang, Britton Chance Center for Biomedical Photonics, Wuhan National Laboratory for Optoelectronics, Huazhong University of Science and Technology.)
B Ins-1 cell MARCS-DsRed (Image courtesy of Dr. Hideo Mogami, Hamamatsu University.)

For detailed information on the effects of multiplicative noise in EM-CCDs compared to Gen II sCMOS sensors, please review our white paper "ORCA-Flash4.0 V2: Changing the Game" at <http://www.hamamatsu.com/all/en/C11440-22CU.html>

Does a little bit more Quantum Efficiency (QE) make a difference?

An easy way to consider this question is to compare two cameras with identical specs except QE. Both cameras have very low read noise of 1.4 e- rms. But Camera A has 82% QE at 560nm and Camera B has 72%. Does this 10% matter? At low light, this higher QE reduces the impact of the read noise. It sounds counterintuitive, but here's the logic.

Generally, read noise for cameras is specified in electrons, which is wavelength independent. But light is the thing we are measuring and we believe it should be reported in photons. It is the relationship of the camera noise to the QE at the wavelength of interest that holds the key to understanding why the effective read noise is different in the two cases described. The math is simple. For Camera A, this would translate into $1.4 \text{ e-} / .82$ or 1.7 photons and for Camera B its 1.9 photons. That's actually a 14% higher read noise in Camera B and this difference can be relevant for very low light imaging. The reality is that many biological samples enough are bright enough for this read noise difference to be inconsequential. But at these low-to-mid intensities, where the answers to many complex biological questions exist, the higher QE contributes to better overall signal to noise and provides the practical capability to increase frame rates, reduce illumination intensity or shorten exposures without sacrificing SNR.

Read noise: rms or median?

RMS and median are both valid statistical models for evaluating the central tendencies of data distributions, such as pixel noise. With CCDs there are never any issues regarding which model to use because the typical read noise for all pixels is very similar; thus rms and median are equivalent. With sCMOS, the structure of the sensor inherently has more pixel variation and the extreme low noise of the sensor makes variation more statistically significant.

But when it comes to evaluating camera performance, the truly meaningful spec is rms noise. The rms noise value provides insight into image quality as well as being the appropriate noise variable in quantitative calculations. The ORCA-Flash4.0 V2's median noise data of 1.0 electrons (typical) is included only to facilitate apparent comparison with other sCMOS cameras. For truly quantitative imaging, rms noise must be known. The ORCA-Flash4.0 V2 Gen II sCMOS has 1.6 electrons rms typical read noise.

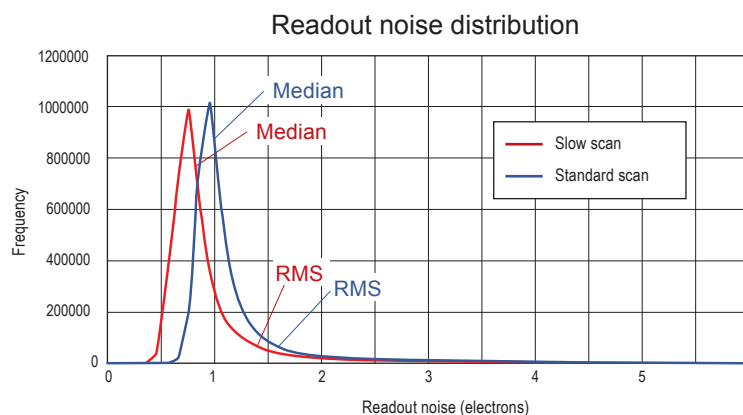

All pixels or some pixels?

RMS or median noise values are valid only if all the pixels in the sensor are used or if the exclusion of outlier pixels is documented and explained. For the ORCA-Flash4.0 V2, we calculate both the rms and median read noise using every pixel in the sensor. This is done without any pixel correction functions or prequalification of the data. Since one goal of providing a spec is to enable accurate quantification of imaging results, this approach is consistent with our goal of providing the best quantitative scientific cameras.

High sensitivity means extreme versatility

The ORCA-Flash4.0 V2 is changing the game of scientific imaging. For years, cooled CCDs have been the go-to technology for fluorescence applications such as GFP or multi-channel imaging that require high signal to noise, high contrast images. EM-CCDs have been scientists' choice for low-light, often high speed applications such as TIRF or spinning disk confocal. For lack of a better choice, the same technology has been adopted for localization microscopy. The ORCA-Flash4.0 V2 offers such a multitude of benefits that it not only easily accomplishes each of these applications -- it may do them better.

Fan Long, Shaoqun Zeng, and Zhen-Li Huang. "Localization-based super-resolution microscopy with an sCMOS camera Part II: Experimental methodology for comparing sCMOS with EMCCD cameras," Optics Express, Vol. 20, Issue 16, pp. 17741-17759 (2012) <http://dx.doi.org/10.1364/OE.20.017741>

Quantum efficiency: 82 % peak QE

The ORCA-Flash4.0 V2 is engineered to outperform all other cameras for fluorescence microscopy. With carefully designed pixels and on-chip lens technology, its Gen II sCMOS sensor provides high QE across the range of wavelengths most commonly used in fluorescence microscopy.

Low noise

The ORCA-Flash4.0 V2 has the lowest read noise at 100 frames/s of any CCD or sCMOS camera. Even EM-CCDs trade off “relative” low read noise for multiplicative noise by using on-chip gain. But the ORCA-Flash4.0 V2 requires no tradeoffs. Our “quiet” electronics successfully lower the limit of detection, allowing you to take full advantage of high frame rates and see your signal with fewer photons. The unique combination of high quantum efficiency and low noise, in the absence of EM-CCD multiplicative noise, means that your images are not limited by the camera. Detect signal at low light levels, compare small changes in intensity, and discriminate small signals amid large backgrounds—with ease.

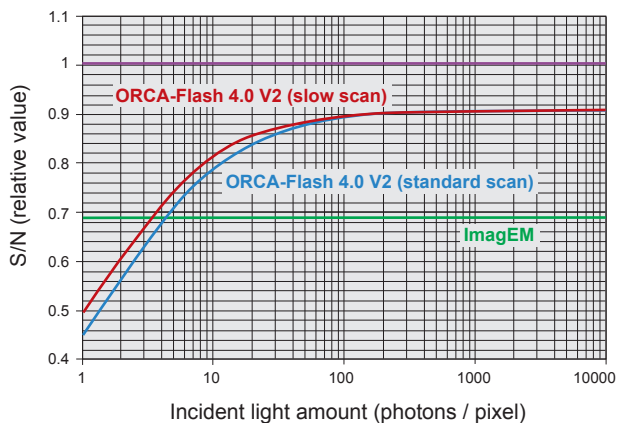
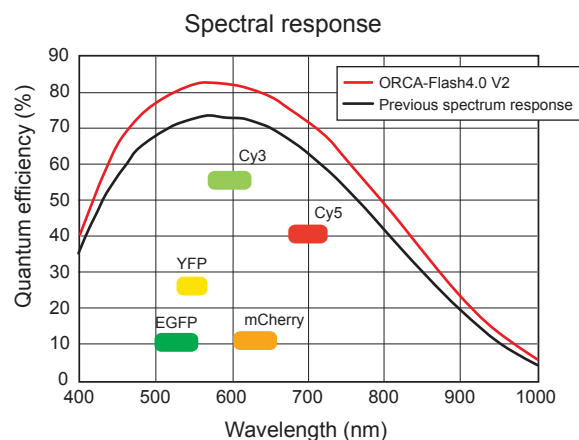

The above graph represents the relative SNR comparison between the ORCA-Flash4.0 V2 and EM-CCD. The ORCA-Flash4.0 V2 has higher SN than EM-CCD with input photon numbers of 4 photons per pixel.



Conduct your research

Every ORCA-Flash4.0 V2 includes ImageConductor connectivity™ so that it's enabled for both USB 3.0 (default) and high speed Camera Link. If your imaging tempo is 30 frames/s, then the default configuration with USB 3.0 is right for you. If you need something a little more lively... presto, just add a Camera Link board now or later to achieve 100 frames/s of full 4-megapixel images. Both options deliver the same low noise, high quantum efficiency imaging for unprecedented sensitivity. With Hamamatsu's versatile ImageConductor connectivity™ you direct the show.

Wide field of view & high resolution

With 4.0 megapixels at $6.5 \mu\text{m} \times 6.5 \mu\text{m}$ each, the ORCA-Flash4.0 V2 is the ideal format for demanding microscopy applications. Whether imaging at high magnification, requiring finely detailed images of an individual cell, or low magnification, aiming to capture and resolve images of many cells, the ORCA-Flash4.0 V2 delivers beautiful images.

Comparison of field of view

Field of view is 2.5× larger than that of a standard EM-CCD camera.

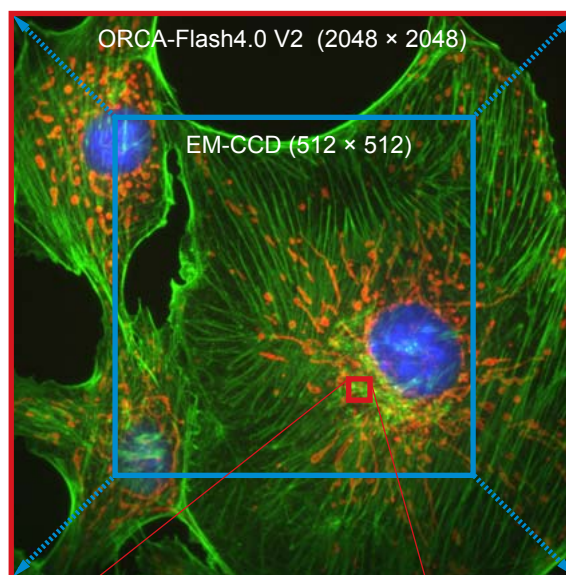

Sample: FluoCells Prepared Slide #1
Objective lens: S Plan Fluor 100×

Comparison of resolution

The $6.5 \mu\text{m} \times 6.5 \mu\text{m}$ pixels of the ORCA-Flash4.0 V2 enable much finer detail to be resolved when compared to the $16 \mu\text{m} \times 16 \mu\text{m}$ pixels of an EM-CCD camera.

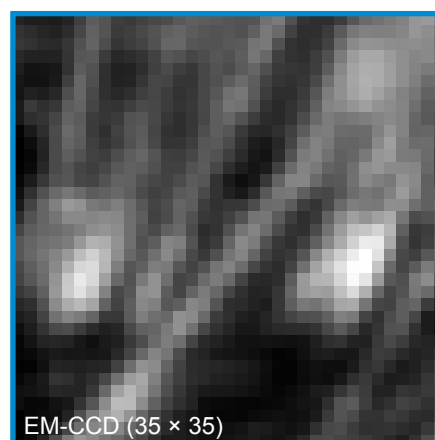
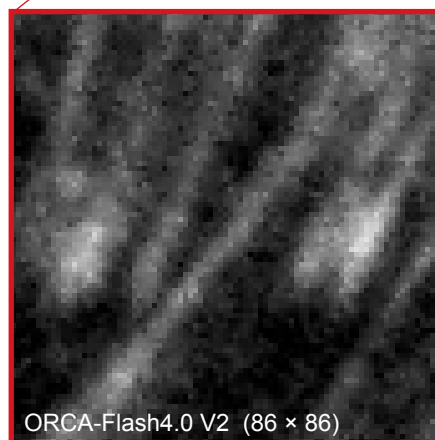

High speed: allegro or presto? You be the Conductor.

When conducting imaging with a camera that has 4194304 pixels with 16-bit data depth, a single image is 8 megabytes. But capturing a single frame is child's play. What really matters is sustained, sequential image capture. Hamamatsu's ImageConductor gives you control over which speed works for you. In the default configuration, the ORCA-Flash4.0 V2 comes with a USB 3.0 card and cable and will deliver 30 frames/s of full frame acquisition. If you choose, upgrade to our fully supported FireBird PCI Express Gen II 8x Camera Link card, and that very same camera, without any additional modifications, can achieve 100 frames/s full resolution speed. Both camera configurations facilitate fine tuning of frame rates by allowing flexible region of interest, letting you select the area that matters. At all speeds, in every configuration, the ORCA-Flash4.0 V2 has just 1.6 electrons rms (1.0 electrons median) read noise for the ultimate in versatility and performance.

Low noise and fast readout time simultaneously

Readout speed		Camera Link		USB 3.0		
		Horizontal pixel	Binning	Horizontal pixel		Binning
		2048 / 1536 / 1024 / 512	2 × 2, 4 × 4	2048 / 1536 / 1024	512	2 × 2, 4 × 4
Vertical line	2048	100	100	30	100	100
	1024	200	200	60	200	200
	512	400	400	120	400	400
	256	801	801	240	801	801
	128	1603	1603	481	1603	1603
	64	3206	3206	968	3206	3206
	8	25 655	25 655	7894	25 655	25 655

Readout speed at center position (frames/s, typ.)

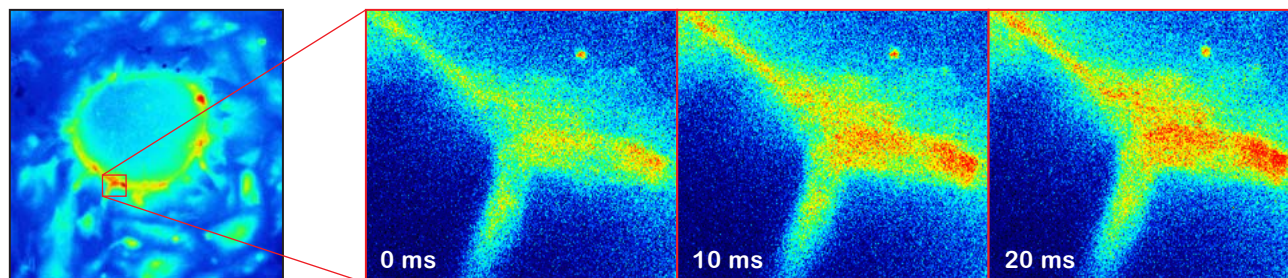

High-speed Ca^{2+} imaging of cardiomyocyte derived from human iPS cell stained with Fluo8-AM. Sequential images were obtained every 10 ms. Left: whole FOV of the ORCA-Flash4.0 V2 image. Right: magnified images show rapid and finely localized changes in intracellular Ca^{2+} concentration associated with cardiomyocyte contractions.

 Specifications

Product number		C11440-22CU
Imaging device		Scientific CMOS sensor
Effective number of pixels		2048(H) × 2048(V)
Cell size		6.5 μm × 6.5 μm
Effective area		13.312 mm × 13.312 mm
Full well capacity (typ.)		30 000 electrons
Readout time	Standard scan (at 100 frames/s)	10 ms
	Slow scan (at 30 frames/s)	33 ms
Readout noise	Standard scan (at 100 frames/s, typ.)	1.6 electrons rms (1.0 electrons median)
	Slow scan (at 30 frames/s, typ.)	1.4 electrons rms (0.8 electrons median)
Dynamic range (typ.)*2		37 000:1
Quantum efficiency		82 % peak QE

Cooling method	Dark current (typ.)	Sensor temperature (nominal)
Forced air (Ambient at +20 °C)	0.06 electrons/pixel/s	-10 °C
Water (+20 °C)	0.02 electrons/pixel/s	-20 °C
Water (+15 °C)	0.006 electrons/pixel/s	-30 °C

Frame rate	Camera Link	USB 3.0
Full resolution	100 frames/s	30 frames/s
2048 × 1024 (at center position)	200 frames/s	60 frames/s
2048 × 8 (at center position)	25 655 frames/s	7894 frames/s
512 × 8 (at center position)	-	25 655 frames/s

Lightsheet Readout Mode (Camera Link only)	
Readout format	Seamless readout
Readout direction	Top to bottom / Bottom to top
Readout time	20 ms to 204.8 s (at full area readout)
Scan mode	Full area, Sub-array

A/D conversion*3	16 bit output	
Readout modes	Digital binning 2 × 2 / 4 × 4	
	Sub-array readout mode	
Exposure time*4	Internal trigger mode (at full resolution)	1 ms to 10 s
	Internal trigger mode with sub-array readout	38.96 μs to 10 s
	External trigger mode with sub-array readout	1 ms to 10 s
Digital interface	Camera Link *5 / USB 3.0	
Lens mount	C-mount	
Power requirement	AC 100 V to AC 240 V, 50 Hz/60 Hz	
Power consumption	Approx. 70 VA	

Trigger in	
External trigger mode	Edge, Level, Synchronous readout, Start trigger, Global reset edge and Global reset level
External trigger signal routing	SMA connector or Camera Link I/F
External trigger delay function	0 to 10 s in 10 μs steps

Trigger out	
External signal output	3 programmable timing outputs
	Global exposure timing and trigger ready output
External signal output routing	SMA connector

Software	
Software interface	PC-based acquisition package included
	DCAM-SDK, commercially available software

*2 Full well capacity / Readout noise median in slow scan

*3 The true 16 bit image data is achieved through seamless merging of the output from two 11 bit A/D converters.

*4 Minimum exposure time in internal trigger mode varies depending on sub-array setting. Minimum exposure time is in standard scan.

*5 Proprietary mode equivalent of Camera Link 80-bit configuration

Dimensional outlines

Camera (Approx. 2.0 kg)

Unit: mm

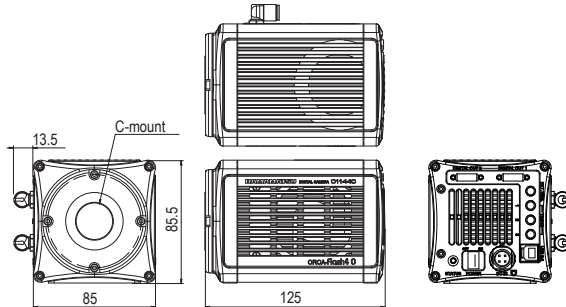

Configuration example

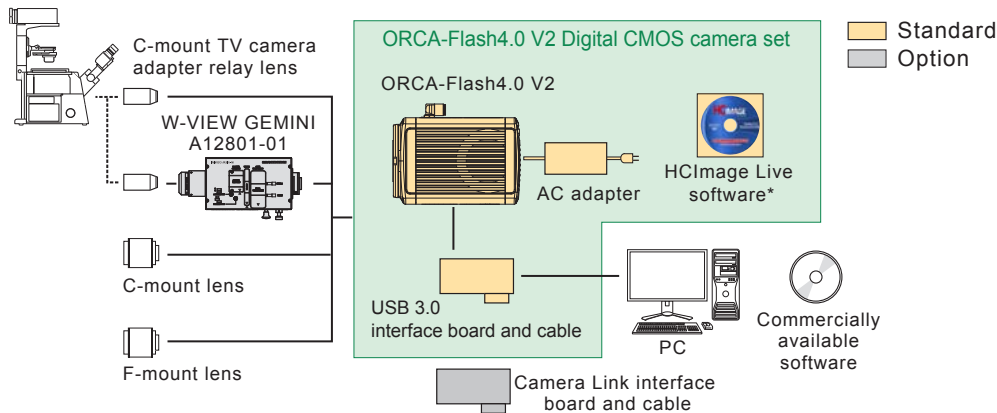

* HCImage Live software provides standard image measurement functions. Upgrades to more feature-rich versions are available.

Please contact your local Hamamatsu representative or distributor regarding actual configuration.



W-VIEW GEMINI Image Splitting Optics A12801-01 (Option)

The W-VIEW GEMINI is an image splitting optics which provides one pair of dual wavelength images separated by a dichroic mirror onto a single camera. Simultaneous image acquisition of dual wavelength images allows you high speed ratio metric imaging and other multiple fluorescence applications.

Cover image: Rat hippocampal neurons and glial fixed and immunostained with antibodies against HDAC6, GFAP and Synapsin1&2. Courtesy of Qi Zhang, Ph.D., Vanderbilt University <http://www.mc.vanderbilt.edu/labs/nano-neurosci/>

ORCA is registered trademark of Hamamatsu Photonics K.K. (France, Germany, Japan, U.K., U.S.A.)
 HCIMAGE is registered trademark of PHOTONICS MANAGEMENT CORP. (Australia, China, EU, Japan, Norway, Singapore, Switzerland, U.S.A.)
 Product and software package names noted in this documentation are trademarks or registered trademarks of their respective manufacturers.

- Subject to local technical requirements and regulations, availability of products included in this promotional material may vary. Please consult your local sales representative.
- Information furnished by HAMAMATSU is believed to be reliable. However, no responsibility is assumed for possible inaccuracies or omissions.
- Specifications and external appearance are subject to change without notice.

© 2015 Hamamatsu Photonics K.K.

HAMAMATSU PHOTONICS K.K. www.hamamatsu.com

HAMAMATSU PHOTONICS K.K., Systems Division

812 Joko-cho, Higashi-ku, Hamamatsu City, 431-3196, Japan, Telephone: (81)53-431-0124, Fax: (81)53-435-1574, E-mail: export@sys.hpk.co.jp

U.S.A.: Hamamatsu Corporation: 360 Foothill Road, Bridgewater, N.J 08807, U.S.A., Telephone: (1)908-231-0960, Fax: (1)908-231-1218 E-mail: usa@hamamatsu.com
 Germany: Hamamatsu Photonics Deutschland GmbH.: Arzbergerstr. 10, D-82211 Herrsching am Ammersee, Germany, Telephone: (49)8152-375-0, Fax: (49)8152-265-8 E-mail: info@hamamatsu.de
 France: Hamamatsu Photonics France S.A.R.L.: 19, Rue du Saule Trapu, Parc du Moulin de Massy, 91882 Massy Cedex, France, Telephone: (33)1 69 53 71 00, Fax: (33)1 69 53 71 10 E-mail: infos@hamamatsu.fr
 United Kingdom: Hamamatsu Photonics UK Limited: 2 Howard Court, 10 Tewin Road, Welwyn Garden City, Hertfordshire AL7 1BW, UK, Telephone: (44)1707-294888, Fax: (44)1707-325777 E-mail: info@hamamatsu.co.uk
 North Europe: Hamamatsu Photonics Norden AB: Torshamnsgatan 35 16440 Kista, Sweden, Telephone: (46)8-509-031-00, Fax: (46)8-509-031-01 E-mail: info@hamamatsu.se
 Italy: Hamamatsu Photonics Italia S.r.l.: Strada della Moia, 1 int. 6 20020 Arese (Milano), Italy, Telephone: (39)02-93581733, Fax: (39)02-93581741 E-mail: info@hamamatsu.it
 China: Hamamatsu Photonics (China) Co., Ltd.: B1201 Jiaming Center, No.27 Dongsanhuan Beilu, Chaoyang District, Beijing 100020, China, Telephone: (86)10-6586-6006, Fax: (86)10-6586-2866 E-mail: hpc@hamamatsu.com.cn

Cat. No. SCAS0081E14
 OCT/2015 HPK Created in Japan